



# CRANE SCALES

## CRS SERIES



Model:

CRS-500/1000  
CRS-1000/2000

### Product features

- ✓ Available in 1000 and 2000 lb capacity
- ✓ Large LCD display with backlight
- ✓ Toogles Between Kg and Lb
- ✓ Tare function
- ✓ Durable aluminum construction
- ✓ Ideal for manufacture industry

### Product highlights



Wireless Remote control



Tare function



Rugged structure

### Certifications



### Warranty





# CRANE SCALES

## CRS SERIES

### Dimensions

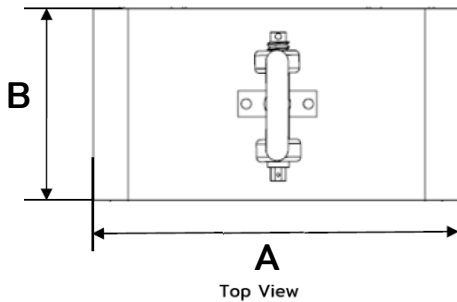
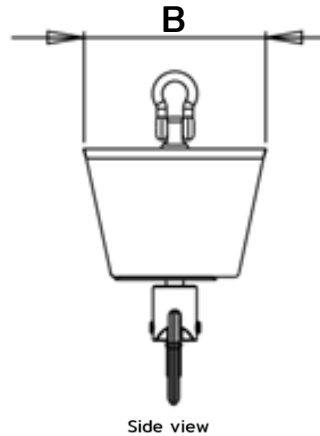
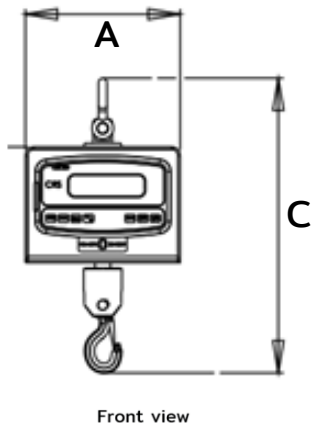

MODEL	A	B	C
CRS-HD 500/1000	8.00 "	8.25 "	15.00 "
CRS-HD 1000/2000	8.00"	8.25"	16.50"

Table 1

### Technical specifications

#### Dimensions CSR-500/1000 , CRS-1000/2000

External dimensions	See table 1
Packing dimensions	W: 14.76 " D:10.23 " H: 7.48"
Net weight	9.00 lb
Total weight (packing included)	18.73 lb

#### Construction

Material	Aluminun construction.

#### Logistic data

Units per pallet	108
Weight per pallet	2063.52 lb
Dim. Per pallet	44.88" x 51.96" x 103.54"
Storage temperature	-4°F to 122°F (-20°C to 50°C)

#### Electrical data

Power supply	100-240 Vca / 47/63 Hz
Ampers	0.2 A
Cord length	70.86"
Lighting	LED
Plug type	NEMA-5-15P
Display	LCD display with backlight

#### Performance data

Capacity	1000.00 lb
Minimal division	0.05 lb
Max. Tare	500.00 lb

#### Additional data

Operation temperature	14°F to 104°F (-10°C to 40°C)