



Shipping / Receiving scale

EQB SERIES



Models:
EQB 50/100
EQB 100/200

Product features

- Available in 100 and 200 lb capacities
- LED display with backlight
- Heavy duty platform
- Robust stainless steel construction
- 100 hours rechargeable battery
- Toggles between kilograms and pounds
- Tare function
- RS 232 serial communication

Product highlights



Robust Steel construction



Large solid plate



Big display

Certifications



Warranty





Shipping / Receiving scale

EQB SERIES

Dimensions

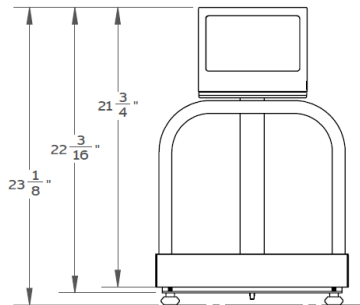

Front view

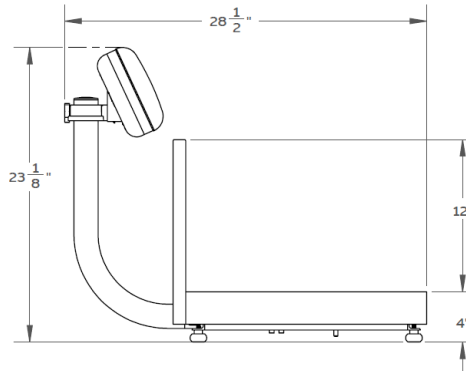

Side view

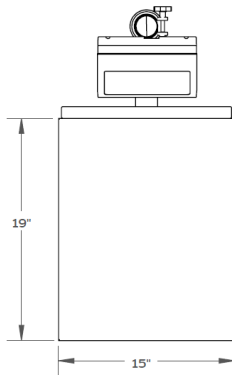

Top View

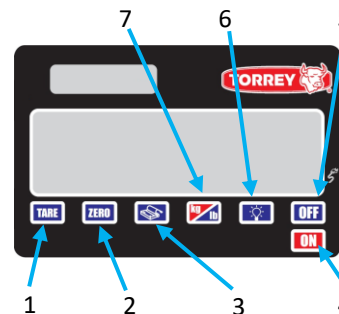

Keypad Overview

- 1- TARE
- 2- ZERO
- 3- PRINT KEY
- 4- ON
- 5- OFF
- 6- LCD BACKLIGHT ON/OFF
- 7- UNITS MEASURE SWITCH KEYS

Technical specifications

Dimensions

External dimensions	W: 15" D: 28.5" H: 23.125"
Packaging dimensions	W: 25.59" D: 27.95" H: 9.05"
Gross weight	24 lb
Shipping Weight	30 lb
Plate dimensions	W: 15" D: 19" H: 4"

Construction

Scale Construction	Carbon steel construction
Platform Construction	Carbon steel construction
Plate holder material	Carbon steel construction
Leveling feet	4

Logistic data

Units per pallet	28
Weight per pallet	961.2 lb.
Dim. per pallet	44.88" X 48" X 48.81"

Electrical data

Power supply	110/220VAC - 6VDC 500mA
Battery	Rechargeable Battery 4.5V, 2.5A/h
Battery Life	100 Hours (no backligh) Aprox 6 Hours (Suspend mode)
Charging time	12 Hours
Display	LCD with Backligh

Performance data

Capacity	100 lb / 200 lb
Minimal division	0.02 lb / 0.05 lb
Maximum tare	100 lb / 200 lb
Operation temperature	14°F to 104°F (-10°C to 40°C)
Storage temperature	-4°F to 122°F (-20°C to 50°C)

Additional data

Connectivity	RS232 Serial
Software PC available	Software scale
Accuracy Class	III
Warranty	1 year