



## Portining scale L-EQ HS SERIES

Model:  
**LEQ5-HS**  
**LEQ10-HS**



### Product features

- Available in 10 lb and 20 lb capacity
- Toggles between kg, lb and oz
- Robust stainless steel case and plate
- Audible programable portioning alarm
- 100 hour rechargeable battery
- Progressive tare operation (optional pedal foot for tare operation)
- LCD Display with backlight
- PC communication
- AC Charger (Included)

### Product highlights



Weight display with LCD Backlight



Easy-touch keyboard



Pedal foot for handles tare operation

### Certifications



### Warranty





# Portining scale

## L-EQ HS SERIES

### Dimensions

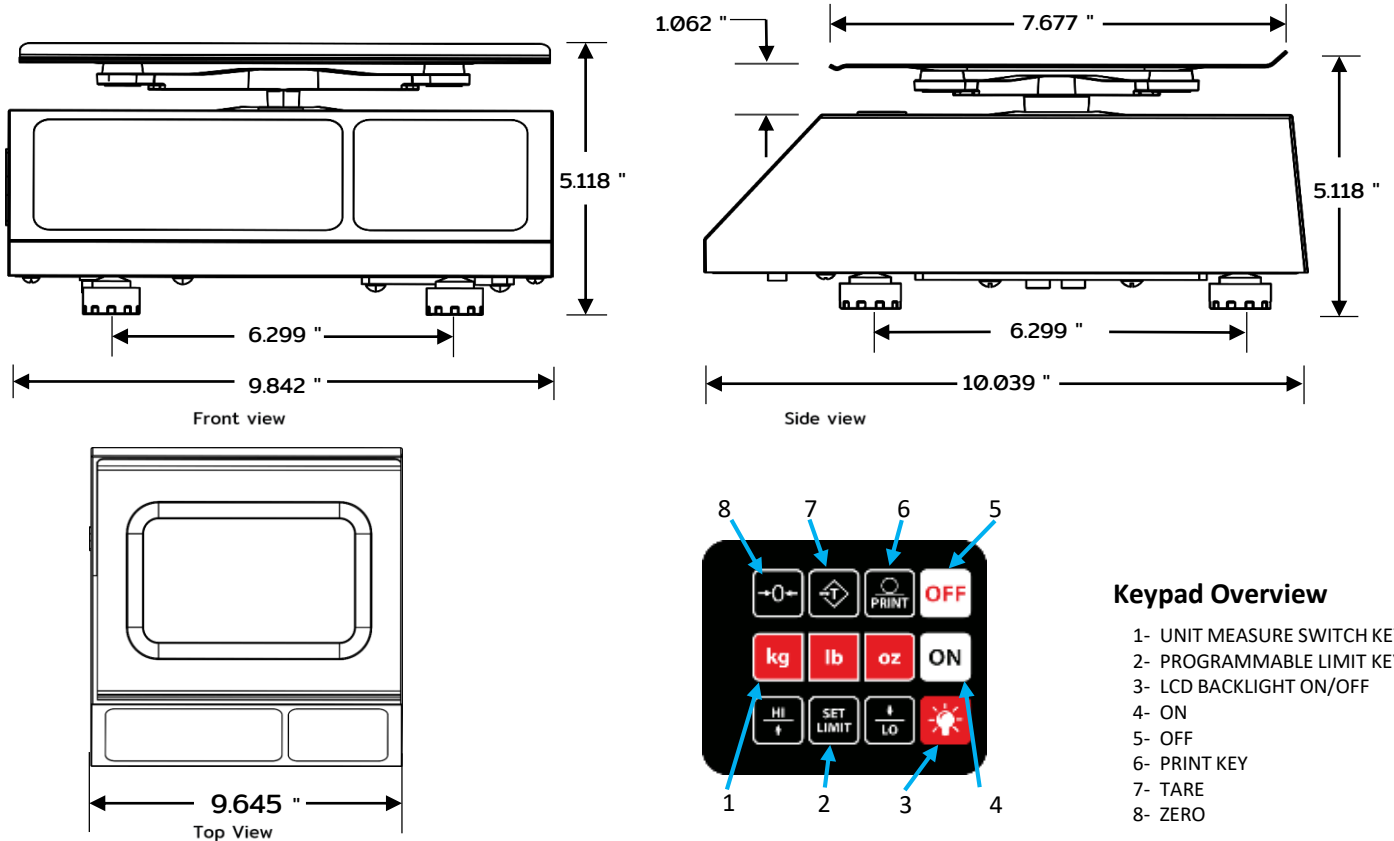

### Technical specifications

#### Dimensions

<b>External dimensions</b>	W: 9.842" D: 10.039" H: 5.118"
<b>Packaging dimensions</b>	W: 12.598" D: 12.204" H: 7.48"
<b>Gross weight</b>	11.023 lb.
<b>Shipping Weight</b>	6.17 lb.
<b>Plate dimensions</b>	W: 9.585" D: 7.677" H: 0.320"

#### Construction

<b>Scale Construction</b>	Food grade stainless steel
<b>Platform Construction</b>	Food grade stainless steel
<b>Plate holder material</b>	High strength reinforced plastic
<b>Leveling feet</b>	4

#### Logistic data

<b>Units per pallet</b>	90
<b>Weight per pallet</b>	933 lb.
<b>Dim. per pallet</b>	44.881" X 48.031" X 82.677"

#### Electrical data

<b>Power supply</b>	110/220VAC - 6VDC 500mA
<b>Battery</b>	Rechargeable Battery 4VDC 2.5A/h
<b>Battery Life</b>	100 Hours (no backligh) Aprox 6 Hours (Suspend mode)
<b>Charging time</b>	12 Hours
<b>Display</b>	LCD with Backligh

#### Performance data

<b>Capacity</b>	10 lb / 20 lb
<b>Minimal division</b>	0.002 lb / 0.005 lb
<b>Maximum tare</b>	10 lb / 20 lb
<b>Operation temperature</b>	14°F to 104°F (-10°C to 40°C)
<b>Storage temperature</b>	-4°F to 122°F (-20°C to 50°C)

#### Additional data

<b>Connectivity</b>	RS232 Serial
<b>Pedal foot dimensions</b>	W: 2.63" D: 4.015" H: 1.05"
<b>Pedal foot cord lengths</b>	83"
<b>Accuracy Class</b>	III
<b>Warranty</b>	1 year