



Portining scale

PZC SERIES

Model:
PZC-5/10
PZC-10/20



Product features

- Available in 10 lb and 20 lb capacity
- Toggles between kg, lb and oz with one button
- Robust stainless steel case and plate
- 100 hours duration rechargeable battery
- Pedal foot for tare operation (optional)
- Turret for elevated display
- Tare function

Product highlights

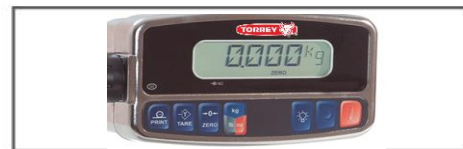

LCD display and backlight



Adjustable display



Pedal foot for handsless operation

Certifications



Warranty





Portining scale

PZC SERIES

Dimensions

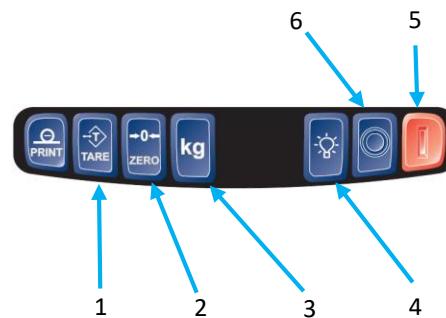
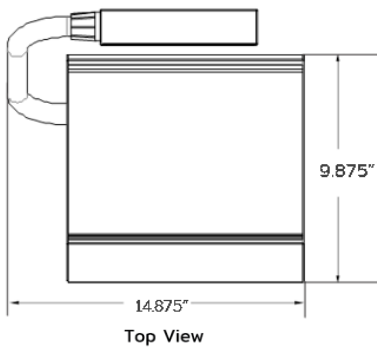
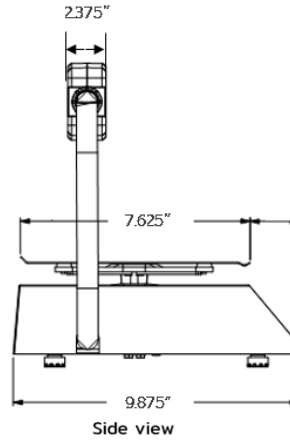
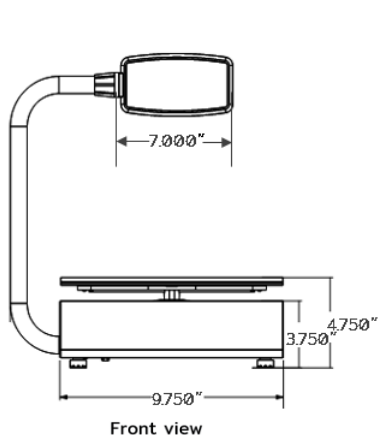

Keypad Overview

- 1- TARE KEY
- 2- ZERO KEY
- 3- UNITS KEY
- 4- OFF KEY
- 5- ON KEY
- 6- BACKLIGHT KEY

Technical specifications

Dimensions

| | |
|-----------------------------|------------------------------|
| External dimensions | W: 14.87" D: 14.05" H: 5.47" |
| Packaging dimensions | W: 17.32" D: 17.32" H: 8.66" |
| Gross weight | 10.9 lb. |
| Shipping Weight | 15.43 lb. |
| Plate dimensions | W: 7.80" D: 9.60" H: 1.00" |

Construction

| | |
|------------------------------|----------------------------------|
| Scale Construction | Food grade stainless steel |
| Platform Construction | Food grade stainless steel |
| Plate holder material | High strength reinforced plastic |
| Leveling feet | 4 |

Logistic data

| | |
|--------------------------|--------------------------|
| Units per pallet | 40 |
| Weight per pallet | 616 lb. |
| Dim. per pallet | 44.88" X 51.96" X 78.74" |

Electrical data

| | |
|----------------------|---|
| Power supply | 110/220VAC - 9VDC 500mA |
| Battery | Rechargeable Battery 6V, 950mA/h |
| Battery Life | 100 Hours (no backligh) Aprox 6 Hours (Suspend mode) |
| Charging time | 12 Hours |
| Display | LCD with Backlight |

Performance data

| | |
|------------------------------|-------------------------------|
| Capacity | 10 lb / 20 lb |
| Minimal division | 0.002 lb / 0.005 lb |
| Maximum tare | 10 lb / 20 lb |
| Operation temperature | 14°F to 104°F (-10°C to 40°C) |
| Storage temperature | -4°F to 122°F (-20°C to 50°C) |

Additional data

| | |
|--------------------------------|-----------------------------|
| Pedal foot dimensions | W: 2.63" D: 4.015" H: 1.05" |
| Pedal foot cord lengths | 83" |
| Accuracy Class | III |
| Warranty | 1 year |